

[CONTRIBUTION FROM THE CHEMICAL LABORATORY OF HARVARD COLLEGE.]

## A REVISION OF THE ATOMIC WEIGHT OF PHOSPHORUS.

[SECOND PAPER.]

## THE ANALYSIS OF PHOSPHORUS TRIBROMIDE.

BY GREGORY PAUL BAXTER, CHARLES JAMES MOORE AND ARTHUR CLARENCE BOYLSTON.

Received January 12, 1912.

In a recent investigation by Baxter and Jones<sup>1</sup> upon the atomic weight of phosphorus by the analysis of trisilver phosphate, the constant in question was found to have the value 31.04 if silver has the atomic weight 107.88, or 31.03 if silver is given the value 107.87. While this result is in good accord with those of most earlier experimenters in the same field, Ter Gazarian,<sup>2</sup> on the other hand, from the density of phosphine, has recently obtained a considerably lower value, 30.91. So large a difference as this obviously needs explanation, and the most promising method of solving the problem seemed to be to analyze some other compound of phosphorus.

In the research upon silver phosphate some uncertainty was introduced by the fact that the salt contains only 7.7% of phosphorus, so that the percentage error in determining the molecular weight of silver phosphate is many times multiplied in the calculation of the atomic weight of phosphorus. In this respect phosphorus tribromide is somewhat better suited for the purpose, since it contains 11.5% of phosphorus. Hence, in spite of very considerable difficulties in the preparation of the tribromide in a pure state, and in its analysis, we were led to choose this substance for further investigation of the subject.

In outline the method followed was to synthesize phosphorus tribromide by the action of pure, dry bromine on pure, dry phosphorus in a vacuum. The product, which contained a slight excess of bromine, was fractionally distilled in a vacuum, and as soon as the excess of bromine had been eliminated various fractions were collected and analyzed for bromine in the usual way, after decomposition with water and oxidation of the phosphorous acid was produced.

#### Purification of Materials.

*Water.*—All the water used in this research was prepared from the laboratory supply of distilled water by further distillation, first from an alkaline permanganate solution, and then a second time, after the addition of a trace of sulfuric acid, through a block-tin condenser. No rubber or cork was used in the connection between the condenser tube and the Jena glass still.

*Ammonia.*—The best commercial ammonia was distilled into the purest water.

<sup>1</sup> *Proc. Am. Acad.*, 45, 137 (1910). *THIS JOURNAL*, 32, 298. *Z. anorg. Chem.*, 66, 97.

<sup>2</sup> *J. chem phys.*, 7, 337 (1909); 9, 101 (1911).

*Nitric Acid.*—C. P. concentrated acid was distilled through a platinum condenser, with rejection of the first two-thirds of the distillate. It was always carefully tested in a nephelometer for traces of halogens.

*Bromine.*<sup>1</sup>—This substance was freed from all but a trace of chlorine by distillation from solution in a concentrated solution of potassium bromide. The product was next converted into potassium bromide by addition to a solution of recrystallized potassium oxalate. In order to remove iodine the solution of potassium bromide was boiled for some time, with the occasional addition of small amounts of the partially purified bromine which had been saved for this purpose. Toward the end of the boiling several small portions of potassium permanganate and sulphuric acid were added to remove last traces of iodine. Next the solution was evaporated to dryness and the dry salt was fused in a large platinum crucible to destroy organic matter. From the fused potassium bromide bromine was prepared as needed by solution in water and the addition of sufficient potassium permanganate and sulphuric acid to oxidize three-fourths of the bromide. In this process the bromine was distilled a second time from a bromide, and since this bromide was already nearly pure, last traces of chlorine must have been eliminated from the product. The bromine was separated as far as possible from water, and was dried by resublimed phosphorus pentoxide, from which it was distilled immediately before use. A quantity of bromine which had been thus treated was evaporated on a steam bath in a glass dish, which was then tested for residual phosphoric acid with negative results.

*Phosphorus.*—The method used for purifying the phosphorus was distillation with steam. In the case of the phosphorus from which the tribromide for the first series of analyses was prepared, the distillation was assisted by a current of carbon dioxide, and was not repeated. The phosphorus used for the second and third series of analyses was twice distilled with steam, the greater portion at atmospheric pressure, a small portion at reduced pressure, in an apparatus constructed wholly of glass. The purified material was preserved under water until used. Portions of these specimens were carefully tested for arsenic by the Berzelius-Marsh method and were found to contain less than one part in one million of the latter element. We are indebted to Mr. W. A. Boughton for carrying out these tests.

*Silver.*—Pure silver was prepared by methods which have already been found to be very effective. Since these methods have been described in detail several times in papers from this laboratory,<sup>2</sup> only a

<sup>1</sup> For a discussion of methods for purifying bromine see Richards and Wells, *Proc. Am. Acad.*, 41, 440 (1906). Baxter, *Ibid.*, 42, 204 (1906); *THIS JOURNAL*, 28, 1325; *Z. anorg. Chem.*, 50, 392.

<sup>2</sup> See especially Richards and Wells, *Pub. Car. Inst.*, No. 28, 16 (1905); *THIS JOURNAL*, 27, 472; *Z. anorg. Chem.*, 47, 70.

brief outline of the procedure is given here. Heterogeneous silver residues were reduced with zinc and sulfuric acid, and thoroughly washed with water. The metal was dissolved in nitric acid, and silver chloride was precipitated by a large excess of hydrochloric acid. After the precipitate had been washed it was dissolved in ammonia and reprecipitated with hydrochloric acid. The resulting chloride was reduced with an alkaline sugar solution and the metal was fused on charcoal. After cleansing with sand and etching with nitric acid, the buttons were dissolved in nitric acid, and the metal was precipitated with pure ammonium formate. The thoroughly washed product was fused with a blowpipe on a crucible of the purest lime. Electrolytic deposition with silver nitrate as the electrolyte and with a dissolving anode of the pure silver buttons followed, and the electrolytic crystals were fused in a current of pure hydrogen on a boat of the purest lime provided with compartments so that the resulting buttons weighed from two to ten grams. After the buttons had been etched with nitric acid until their surfaces were uniformly crystalline, they were thoroughly washed with ammonia and pure water, and finally heated to  $400^{\circ}$  in a vacuum. The pure silver was preserved in a desiccator over fused potassium hydroxide.

*Hydrogen Peroxide.*—Merck's "Perhydrol," containing 30% hydrogen peroxide, was found to be free from sulfuric acid and halogens and to leave no residue upon evaporation. Hence it was employed without further treatment.

*Nitrogen.*—Atmospheric nitrogen free from oxygen was obtained by Wanklyn's well known method of passing air through very concentrated ammonia solution, and then over hot copper gauze in a hard glass tube. The excess of ammonia was removed by scrubbing with a dilute solution of sulfuric acid in three large gas-washing bottles. Since hydrogen is formed by the catalytic decomposition of a portion of the excess of ammonia, this impurity was oxidized in a hard glass tube filled with red hot copper oxide, and the gas was then dried in six towers filled with beads drenched with concentrated sulfuric acid and a long tube filled with resublimed phosphorus pentoxide. Finally the gas was passed through a third hard glass tube filled with hot copper to combine with any last trace of oxygen. The apparatus in which these operations were carried out was constructed entirely of glass with ground glass connections throughout.

#### Preparation of Phosphorus Tribromide.

Much time was consumed in finding a satisfactory method of preparing pure phosphorus tribromide. It was obvious at the outset that the substance must be rigorously protected from access of moisture, in order to avoid the formation of hydrobromic and phosphorous acids. This object was most simply gained by synthesizing the tribromide in a vacuum

from bromine and phosphorus which were initially dry. But since phosphorus dissolves in its tribromide, and can not be readily separated from the latter substance by distillation, an excess of bromine was added at the beginning. Fortunately it was necessary to add only a slight excess of bromine, since a surprisingly small amount of phosphorus pentabromide can be detected in the tribromide by its darker color, especially at high temperatures. This dark color is undoubtedly due in large part to dissociation of the pentabromide into tribromide and bromine. The comparatively easy elimination of the pentabromide from the tribromide also depends upon this dissociation, for the free bromine can be removed by distillation in the first fractions.

At first the attempt was made to remove the excess of bromine by distillation from red phosphorus. But either the red phosphorus still contained traces of the yellow modification, or else the red modification dissolved in the tribromide and vaporized with it when distilled (possibly as a lower bromide<sup>1</sup>). At any rate the tribromide prepared in this way contained far too little bromine, as was shown by the results of its analysis.

Much better results were obtained by simple distillation in a vacuum. Although the boiling point of the tribromide is thus much lowered, the dissociation of the pentabromide is sufficiently complete to secure rapid elimination of the excess of bromine. As stated before, the disappearance of the bromine can be followed by the color of the distillate and residue. If material is collected for analysis as soon as the bromine has apparently been eliminated, it should yield at any rate a minimum value for the atomic weight of phosphorus, unless decomposition of the tribromide into a lower bromide occurs during the distillation. In the latter case, however, the composition of different fractions of the distillate would probably not be constant.

The synthesis of the tribromide was effected in an apparatus constructed entirely of glass shown in the figure on page 263. About 14 grams of pure phosphorus were freed as completely as possible from water by cooling and pressing between folds of hardened filter paper. The phosphorus was weighed to a centigram and placed in the distilling flask D, which had previously been filled with nitrogen through the stopcock A. The flask was then fitted to the separating funnel B by means of a well ground and polished joint, C, but it was not connected to the remainder of the apparatus at E, and the capillary tube F opened into the air.

In order to dry the phosphorus completely, the flask was surrounded with boiling water and for four hours a slow current of pure, dry nitrogen was forced in at A and flowed out at the end of the constricted tube F. The melted phosphorus was agitated from time to time by shaking the

<sup>1</sup> Besson and Fournier, *Compt. rend.*, 150, 120 (1910).

flask in order to liberate any steam which might have been entangled mechanically and to bring new material to the surface of the phosphorus. During this operation a portion of the phosphorus distilled into the cool tube F, and a small amount was vaporized into the air. Probably, too, a small amount of acids of phosphorus was produced since slight oxidation of the phosphorus necessarily took place while it was being introduced into the flask. As soon as the phosphorus had been dried in this way, the end of the constricted tube F was sealed, the stopcock A was closed, and the flask, after being cooled, was exhausted as completely as possible through the stopcock S by means of the Töpler pump W. All the ground glass joints were made gas-tight by means of a minimum quantity of syrupy phosphoric acid, and outside this, to prevent the absorption of moisture, soft paraffin was smeared.

Next the calculated amount of pure, dry bromine was measured from a buret into the separatory funnel B and the funnel was stoppered. After cooling the flask containing the phosphorus with ice water to reduce the violence of the reaction, bromine was slowly admitted. The rapid evaporation of a portion of the bromine produced the solidification of the remainder. This solid bromine, upon falling into the flask, reacted violently with the phosphorus until a considerable amount of tribromide had been formed. As

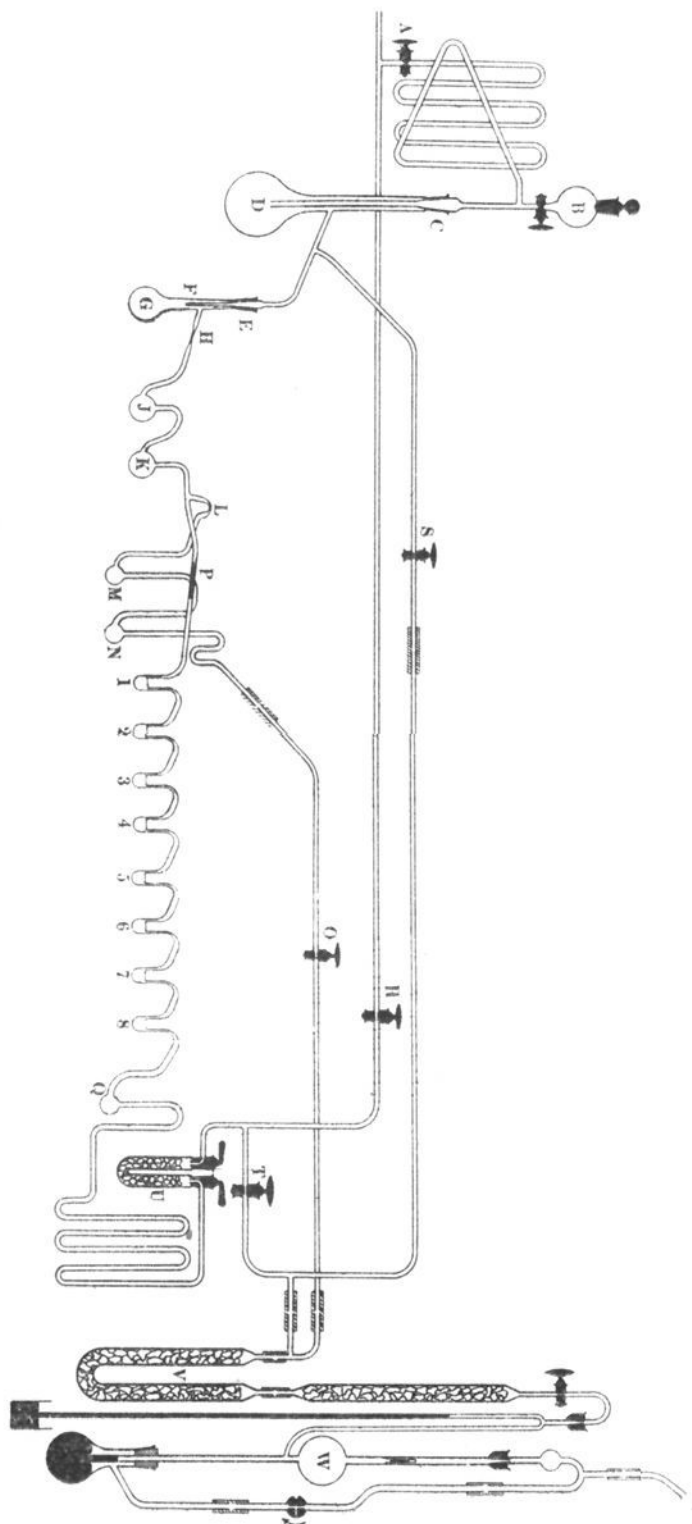

soon, however, as sufficient tribromide had been produced to dissolve the unchanged phosphorus the action became much less violent so that the bromine could be introduced more rapidly.

When nearly the theoretical amount of bromine had been used, the flask D was immersed in hot water in order to decompose a small amount of solid pentabromide which formed in the upper part of the flask. The bromine thus liberated diffused to the bottom of the flask, where it combined with the residual phosphorus dissolved in the tribromide. More bromine was then admitted in very small portions until the warm tribromide acquired the reddish color which indicated an excess of bromine. The end of the reaction can be determined so sharply by the color that the excess of the bromine probably never amounted to more than a few hundredths of a gram, whereas nearly one hundred and twenty-five grams of bromine in all were used in each preparation.

When it was certain that an excess of bromine had been added, the flask D with the tribromide was surrounded with ice water and nitrogen was allowed to enter through A, until the pressure inside the flask was greater than atmospheric. The end of the tube F was then broken off, and the remainder of the apparatus, which had previously been filled with dry nitrogen, was attached by the ground joint E. The flasks D, G, J, K, M and N were next exhausted through O, while the stopcocks A, R, S and T were closed. In order to prevent access of bromine to the mercury of the Töpler pump, a U-tube, V, filled with fused potassium hydroxide was located between the pump and the remainder of the apparatus, and this U-tube was cooled with concentrated calcium chloride solution and ice.

During the fractional distillation of the tribromide to remove the excess of bromine it was highly desirable to protect the bulbs 1 to 8, in which the tribromide was eventually to be collected, from contact with the first fractions. This was effected by passing the first fractions through the side tube L into the bulbs M and N, while the bulbs 1 to 8 were cut off from the rest of the apparatus by the valve P. This valve was so perfectly made that it was nearly gas-tight with no lubricant. Nevertheless, in addition, nitrogen was maintained at atmospheric pressure on the far side of the valve, so that the slight leakage produced a slow reverse current of nitrogen through the valve into the pump by way of the bulbs M and N.

Under as low a vacuum as could be obtained with the pump the tribromide was first distilled from D to G by surrounding D with boiling water and G with ice water. A small residual fraction was left in D, in order to make certain the elimination of phosphorous acid sand possible oxybromide. During this distillation any phosphorus which had originally distilled into the tube F and still remained uncombined was

converted into tribromide by the excess of bromine. A second similar distillation from G to J and K followed, with rejection of the last few grams in G. The material invariably contained an excess of bromine at this point. The capillary tube H was now sealed with a blowpipe and the flasks D and G were thus disconnected from the apparatus. Next the bulbs M and N were cooled with ice and the tribromide in J was boiled while the bulb K was gently warmed. The vapor from J in bubbling through the warm liquid in K carried with it all the excess of bromine in both bulbs. Furthermore, it is probable that if the tribromide contained a trace of hydrobromic acid, the latter substance was eliminated at the same time as the bromine. The distillate collected in M and N as tri- and pentabromide. As soon as ten grams of material had been distilled from J and K the residue, amounting to considerably more than one hundred grams, was nearly colorless; nevertheless five times as much more was distilled into M and N before this part of the apparatus was sealed off at the capillary L. Thus when the stopcock O was closed, the impure distillate was entirely cut off from the remainder of the apparatus.

The bulbs 1 to 8 were then exhausted by opening the stopcocks of the U-tube U and at the point T, while R was closed. The U-tube contained resublimed phosphorus pentoxide to prevent the possibility of back diffusion of moisture into the bulbs. The valve P, into which a piece of soft iron had originally been sealed, could now be pulled from its seat by means of a magnet so that the bulbs J and K were connected with the pump through the bulbs 1 to 8.

In distilling the remainder of the tribromide into the small bulbs the one nearest the pump was filled first by surrounding it with ice water, while the other seven were immersed in beakers filled with boiling water. As soon as bulb 8 was three-fourths filled with material, bulb 7 was cooled with ice water, and so on until all were filled. All the residual material in J and K was distilled into bulb 1.

The train of bulbs 1 to 8 was next sealed off with a blowpipe at the capillaries, and the individual bulbs were separated from the connecting tubes by sealing the capillary tubes. Great care was taken in sealing the capillaries to avoid decomposing the tribromide, by first heating them gently to evaporate any tribromide with which they might be wet. There never was any sign of decomposition of the tribromide during this process.

The final samples of the tribromide were almost colorless when cold, but the very slight yellowish tint of the cold substance was materially increased by a rise in temperature. Since no difference in color could be detected between the first and last samples collected, it seems probable that phosphorus tribromide really possesses a slight yellowish tint.

Two series of samples of tribromide were distilled and sealed in bulbs from two different preparations of material. Ten fractions were collected in the first series and eight in the second.

In a third preparation the removal of the bromine was accelerated by distillation from metallic silver. The bulbs J and K were partly filled with fine electrolytic crystals of the purest silver which had been freed from moisture by ignition in a vacuum. After the tribromide had been distilled into J and K, and the excess of bromine had been distilled into M and N, the capillary tube L was sealed as described before. Then the bulbs J and K with the residual tribromide were warmed for some time with constant shaking before the tribromide was finally distilled into the collecting bulbs.

#### **The Determination of the Weight of the Tribromide and its Analysis.**

In the analysis of the tribromide it was first decomposed with water, and then the bromine was precipitated as silver bromide. The reducing effect of phosphorous acid upon silver salts is well known, so that the necessity was obvious of oxidizing the phosphorous acid. This operation was a somewhat delicate one, however, since the hydrobromic acid also is easily oxidized, with consequent loss of bromine. Hydrogen dioxide was eventually found to be the safest oxidizing agent, although its action on the phosphorous acid is not particularly rapid. In preliminary experiments the bulb of tribromide was broken under water and the oxidation was then effected by hydrogen peroxide in dilute nitric acid solution. In the final experiments the method of breaking the bulb under an ammoniacal solution of hydrogen dioxide was employed, since in this way the greater part of the oxidation was almost instantaneously effected. Then after time the solution was acidified with nitric acid and allowed to stand for a further period. Even then it is probable that oxidation is not quite complete, for if the bromine is precipitated with any considerable excess of silver nitrate, even in the presence of much nitric acid, the silver bromide is perceptibly discolored. On the other hand, if the amount of silver salt used is very nearly equivalent to the bromide present, the precipitate retains its lemon-yellow color even when left for days under the solution.

Since the determination of the weight of the tribromide and its analysis are so intimately connected, they are described together.

The weight of the tribromide was found in each analysis by weighing the bulb with its contents, and then, after breaking the bulb, collecting and weighing the glass. The bulb was first carefully cleaned on the outside and dried, and left in a desiccator over sulphuric acid for at least twenty-four hours. Its weight in air was then found by substituting standardized weights for the bulb on the balance. The buoyant effect of the air was estimated by finding the volume of the bulb



in the usual way from the loss in weight under water of known temperature. The conditions of the atmosphere were taken into account in calculating the buoyant effect of the air on the bulb and weights. Since the bulb was exhausted when sealed no correction is necessary for the space in the bulb not filled with liquid.

After the bulb had been weighed and its volume determined, it was placed in a 300 cc. thick-walled Erlenmeyer flask together with somewhat over 100 cc. of redistilled ammonia and 10 cc. of pure 30% hydrogen dioxide. A glass stopper, which had been carefully ground into the neck of the flask, was inserted, and the flask was shaken violently enough to break the bulb. The heavy tribromide reacted quietly at the bottom of the aqueous solution, until at the end of about five minutes decomposition was complete. The flask was then allowed to stand twenty-four hours, with occasional shaking. This long standing was necessary to allow a small quantity of ammonium bromide fumes to be collected in the aqueous solution.

The flask, cooled to produce inward pressure, was next carefully opened and the solution was filtered into a three-liter ground-stoppered precipitating flask, while the particles of glass were collected upon a small filter paper. This filter was very thoroughly rinsed with pure water until the filtrate and washings amounted to about 1200 cc.

In order to find the weight of the glass the filter was burned at as low a temperature as possible in a weighed platinum crucible. When the weight of the glass, corrected to vacuum, was subtracted from the corrected weight of the bulb and the tribromide, the weight of the tribromide in vacuum was obtained.

In order to make sure that this method of finding the weight of the glass was a satisfactory one, it was tested by several blank experiments with bulbs containing no tribromide. These bulbs were first weighed in the air unsealed, and then were treated in exactly the same way as bulbs containing tribromide. In two cases the fragments of the bulbs were collected upon a weighed Gooch-Munroe-Neubauer crucible. In the first three, however, the glass was collected upon a small filter paper as in the analyses:

Weight of bulb. Grams.	Weight of glass recovered. Grams.	Difference. Gram.
1.20098	1.20097	-0.00001
0.99814	0.99813	-0.00001
1.01851	1.01846	-0.00005
1.12986	1.12994	+0.00008
1.08438	1.08441	+0.00003

Since in every experiment the weight of the glass collected agrees with that of the bulb within 0.00008 gram and is never more than 0.00005 gram less than that of the bulb, it is evident that no important amount

of glass is lost either by passing through the filter paper or by solution in the ammoniacal liquid.

The filtrate containing ammonium bromide was next acidified by the addition of about 40 cc. of concentrated nitric acid diluted to about 300 cc. Since bromine was sometimes locally set free during the addition of the acid, the acid solution was poured into the bromide through a thistle tube, the stem of which extended to the bottom of the flask. Thus, although bromine might be set free at the dividing surface between the bromide and the nitric acid, no bromine ever reached the upper surface of the liquid, owing to the unoxidized phosphorous compounds in the bromide solution. The thistle tube was thoroughly rinsed into the flask, the stopper of the flask moistened and put in place, and the flask gently agitated to mix the solutions. It was then allowed to stand for forty-eight hours. In no case was there any evidence that bromine was permanently set free by the nitric acid, for after the mixing of the solutions they were always colorless, and when the flasks were opened after two days' standing no odor of bromine could be detected, although 0.00001 g. is readily perceptible in 3 liters of air.<sup>1</sup>

During the standing in acid solution the oxidation of the residual phosphorous acid progressed, but even at the end of the period it was not quite complete. Precipitation of the silver bromide immediately after acidification invariably resulted in darkened salt, but after forty-eight hours an apparently pure product was obtained, if no appreciable excess of silver was used.

The bromine in each sample was determined in two ways: first, by finding the amount of silver necessary to combine with it; second, by weighing the silver bromide formed. Both determinations could be carried out with the same sample of tribromide.

A quantity of silver equivalent to the tribromide within a very few tenths of a milligram was weighed out and dissolved in nitric acid in a flask fitted with a column of bulbs to prevent loss of material by spattering. After the silver solution had been freed from oxides of nitrogen by dilution and heating, about 40 cc. of concentrated nitric acid were added and the whole was diluted to a volume of about one liter. The silver solution was then quantitatively added to the bromide solution, with constant agitation, and the stoppered precipitating flask was allowed to stand for several days with occasional shaking. When the precipitate had coagulated and settled so completely that the supernatant liquid was apparently clear, portions of the solution were tested in a nephelometer<sup>2</sup> for excess of bromide or silver. As a matter of fact, bromide was always found in slight excess. The deficiency of silver,

<sup>1</sup> Baxter, Thorvaldson and Cobb, *THIS JOURNAL*, **33**, 329 (1911).

<sup>2</sup> Richards and Wells, *Am. Chem. J.*, **31**, 235 (1904); **35**, 510 (1906).

which was never more than a very few tenths of a milligram, was made up as nearly as could be estimated by means of a hundredth-normal solution of silver nitrate. After thorough shaking and standing until the solution was perfectly clear, tests for excess of bromide or silver were again made. If necessary, this process was repeated, until eventually the amounts of bromide and silver were equivalent. Owing to the slight solubility of silver bromide at this point, the solution remained essentially clear, even in the nephelometer, when either bromide or silver solution was added.

The solution was now allowed to stand for a week with occasional shaking and then was tested again in the nephelometer. Usually a deficiency of one- or two-tenths of a milligram of silver was found, owing apparently to extraction of occluded soluble bromide from the silver bromide. This deficiency of silver was supplied and the solution was left for another week before being tested again, and this process was repeated until in the course of a week no further change in the solution took place. In a few analyses the solutions were tested over a period of four months, but in no case was any appreciable change in the end point found after it had remained constant for a week. In most cases the final end point was reached within two weeks.

The difficulty from occlusion of the silver bromide was unexpected since it has not been met to the same extent in other similar cases in this laboratory.<sup>1</sup> In fact, it was not discovered in this research until Analyses 1, 2, 5, 9, and 10 of Series I had been completed. After its discovery several unsuccessful attempts were made to eliminate the occlusion. In Analyses 6 and 19 the solutions of ammonium bromide and silver nitrate were each diluted to nearly four liters before precipitation. In these two analyses, on account of the large size of the precipitating vessel, no attempt was made to collect the silver bromide, since the results of the comparison with silver were no different from those obtained in more dilute solution. Although occlusion of bromide seemed to be diminished in extent by this modification, the time necessary for the establishment of equilibrium was not materially lessened. Even in Analysis 6, where the bromide solution was added to the silver solution, the occluded substance seemed still to be a soluble bromide. Cooling the solutions to the temperature of ice-water before precipitation seemed to accentuate the occlusion.

As soon as a permanent end point had been reached, the precipitate was thoroughly washed by decantation with pure water and collected upon a weighed Gooch-Munroe-Neubauer crucible. The crucible and contents were heated gradually to nearly 200° and were kept at that

<sup>1</sup> See, however, Richards and Staehler, *THIS JOURNAL*, 29, 632 (1907); *Ber.*, 39, 3618.

temperature for eighteen hours or more. Then they were cooled and weighed by substitution for a similar counterpoise. In order to find the moisture retained by the dried precipitate it was transferred as rapidly and completely as possible to a small porcelain crucible which was immediately weighed with its cover. Then the silver bromide was fused by heating the small crucible contained inside a much larger one. During the solidification of the bromide the system was carefully rotated so that the fused bromide was stirred and caused to solidify in a thin layer. The loss in weight on fusion was then determined. This loss seldom amounted to more than 0.001% of the weight of the salt. The fused bromide was always clear and light yellow, whereas an astonishingly small percentage of impurity is capable of producing perceptible darkening of the salt.

Since silver bromide possesses an appreciable solubility in water,<sup>1</sup> the

SERIES I.							
Ag = 107.880.			PBr <sub>3</sub> : 3Ag.		Br = 79.916.		
No. of analysis.	Fraction of PBr <sub>3</sub> .	Weight of PBr <sub>3</sub> in vacuum. Grams.	Weight of Ag in vacuum. Grams.	Deficiency of Ag. Gram.	Corrected weight of Ag in vacuum. Grams.	Ratio PBr <sub>3</sub> : 3Ag.	Atomic weight of phosphorus.
1	1	5.95293	7.11494	0.00010	7.11504	0.836668	31.031
2	2	4.71056	5.63017	0.00005	5.63022	0.836657	31.028
3	3	4.72373	5.64553	0.00030	5.64583	0.836676	31.034
4	4	6.47622	7.74048	0.00000	7.74048	0.836669	31.031
5	5	4.61956	5.52120	0.00020	5.52140	0.836665	31.030
6	8	7.62060	9.10809	0.00040	9.10849	0.836648	31.025
7	9	3.83321	4.58153	0.00010	4.58163	0.836648	31.025
8	10	4.72578	5.64800	0.00035	5.64835	0.836666	31.030
Average.....						0.836660	31.031

SERIES I.								
PBr <sub>3</sub> : 3AgBr.								
No. of analysis.	Fraction of PBr <sub>3</sub> .	Weight of PBr <sub>3</sub> in vacuum. Grams.	Weight of AgBr in vacuum. Grams.	Loss on fusion. Gram.	AgBr from filtrate and washings. Gram.	Corrected wt. of AgBr in vacuum. Grams.	Ratio PBr <sub>3</sub> : 3AgBr.	Atomic weight of phosphorus.
9	1	5.95293	12.38515	0.00015	0.00060	12.38560	0.480633	31.035
10	2	4.71056	9.79992	0.00011	0.00077	9.80058	0.480641	31.039
11	3	4.72373	9.82782	0.00018	0.00066	9.82830	0.480624	31.031
12	4	6.47622	13.47392	0.00015	0.00051	13.47428	0.480636	31.036
13	5	4.61956	9.61089	0.00005	0.00059	9.61143	0.480632	31.034
14	9	3.83321	7.97524	0.00006	0.00045	7.97563	0.480615	31.025
15	10	4.72578	9.83205	0.00004	0.00060	9.83261	0.480623	31.029
Average.....						0.480629	31.033	

<sup>1</sup> Böttger, *Z. physik. Chem.*, 46, 602 (1903), 0.00008 g. per liter at 20°. Kohlrausch, *Ibid.*, 50, 536 (1905), 0.00011 g. per liter at 21°.

## SERIES II.

Ag = 107.880.

PBr<sub>3</sub> : 3Ag.

Br = 79.916.

No. of analysis.	Fraction of PBr <sub>3</sub> .	Weight of PBr <sub>3</sub> in vacuum. Grams.	Weight of Ag in vacuum. Grams.	Deficiency of Ag. Gram.	Corrected weight of Ag in vacuum. Grams.	Ratio PBr <sub>3</sub> :3Ag.	Atomic weight of phosphorus.
16	1	3.21808	3.84619	0.00030	3.84649	0.836628	31.018
17	2	5.77604	6.90359	0.00020	6.90379	0.836648	31.025
18	5	5.51730	6.59400	0.00056	6.59456	0.836644	31.024
19	6	7.15048	8.54603	0.00050	8.54653	0.836653	31.026
20	7	7.94753	9.49900	0.00030	9.49930	0.836644	31.023
21	8	4.30924	5.15044	0.00030	5.15074	0.836625	31.018
Average.....						0.836640	31.022

## SERIES II.

PBr<sub>3</sub> : 3AgBr.

No. of analysis.	Fraction of PBr <sub>3</sub> .	Weight of PBr <sub>3</sub> in vacuum. Grams.	Weight of AgBr in vacuum. Grams.	Loss on fusion. Gram.	AgBr from filtrate and washings. Gram.	Corrected weight of AgBr in vacuum. Grams.	Ratio PBr <sub>3</sub> :3AgBr.	Atomic weight of phosphorus.
22	1	3.21808	6.69502	0.00015	0.00066	6.69553	0.480631	31.034
23	2	5.77604	12.01740	0.00030	0.00051	12.01761	0.480631	31.034
24	5	5.51730	11.47893	0.00014	0.00067	11.47946	0.480624	31.030
25	7	7.94753	16.53550	0.00032	0.00071	16.53569	0.480629	31.032
26	8	4.30924	8.96560	0.00024	0.00059	8.96595	0.480623	31.029
Average.....						0.480628	31.032	

## SERIES III.

Ag = 107.880.

PBr<sub>3</sub> : 3Ag.

Br = 79.916.

No. of analysis.	Fraction of PBr <sub>3</sub> .	Weight of PBr <sub>3</sub> in vacuum. Grams.	Weight of Ag in vacuum. Grams.	Deficiency of Ag. Gram.	Corrected weight of Ag in vacuum. Grams.	Ratio PBr <sub>3</sub> :3Ag.	Atomic weight of phosphorus.
27	1	4.39626	5.25417	0.00030	5.25447	0.836671	31.032
28	3	7.07758	8.45917	0.00040	8.45957	0.836636	31.021
29	4	4.19854	5.01821	0.00030	5.01851	0.836611	31.013
30	6	7.26540	8.68375	0.00030	8.68405	0.836637	31.021
31	8	7.75072	9.26366	0.00040	9.26406	0.836644	31.023
Average.....						0.836640	31.022
Average of Series I, II and III.....						0.836647	31.025

SERIES III.									
Ag = 107.880.			PBr <sub>3</sub> : 3AgBr.				Br = 79.916.		
No. of analysis.	Fraction of PBr <sub>3</sub> .	Weight of PBr <sub>3</sub> in vacuum. Grams.	Weight of AgBr in vacuum. Grams.	Loss on fusion. Gram.	AgBr from filtrate and wash waters. Gram.	Corrected weight of AgBr in vacuum. Grams.	Ratio PBr <sub>3</sub> :3AgBr.	Atomic weight of phosphorus.	
32	1	4.39626	9.14614	0.00018	0.00067	9.14663	0.480643	31.040	
33	3	7.07758	14.72594	0.00017	0.00055	14.72642	0.480604	31.019	
34	4	4.19854	8.73548	0.00020	0.00058	8.73586	0.480610	31.022	
35	6	7.26540	15.11696	0.00020	0.00049	15.11725	0.480603	31.018	
36	8	7.75072	16.12689	0.00032	0.00080	16.12737	0.480594	31.013	
Average.....							0.480611	31.022	
Average of Series I, II and III.							0.480623	31.029	

filtrate and wash waters were evaporated to small bulk, and after a slight precipitate of silicic acid had been removed by filtration, were diluted to 100 cc. Portions of the solution were then analyzed for silver by comparison in the nephelometer with standard silver nitrate solutions, after the addition of an excess of bromide. In each analysis the amount obtained in this way exceeds slightly the amount to be expected from the solubility of silver bromide, owing doubtless to colloidal silver bromide which escaped the crucibles. A correction for the silver found in this way, estimated as bromide, was added to the weight of the main mass of silver bromide.

The precipitating flask was rinsed with ammonia, and, if the solution was found to contain silver, the quantity was determined in a similar fashion in the nephelometer and a correction applied.

The preceding tables contain the results of all the analyses which met with no accidents. A considerable portion of the preliminary work on the methods of preparation and analysis was done by A. C. Boylston. The perfection of the apparatus and methods and all the final preparations and analyses were made by C. J. Moore.

Weighings were made on a No. 10 Troemner balance sensitive to a very few hundredths of a milligram, while the gold-plated weights were carefully standardized to hundredths of a milligram by the method described by Richards.<sup>1</sup>

Vacuum corrections were applied as follows:

	Specific gravity.	Vacuum correction.
Weights.....	8.3	+0.000145
AgBr.....	6.47	+0.000041
Ag.....	10.49	-0.000030
Glass.....	2.5	+0.000335

The following table, which gives the ratio of silver used to silver bro-

<sup>1</sup> THIS JOURNAL, 22, 144 (1900).

mide obtained in the same analysis, strengthens the view that the precautions taken to prevent reduction of the silver salts by the phosphorous compounds and occlusion by the silver bromide were effective:

Analyses.	Ag: AgBr.
1 and 9	0.574461
2 and 10	0.574478
3 and 11	0.574446
4 and 12	0.574463
5 and 13	0.574462
7 and 14	0.574454
8 and 15	0.574451
16 and 22	0.574486
17 and 23	0.574473
18 and 24	0.574466
20 and 25	0.574473
21 and 26	0.574478
27 and 32	0.574470
28 and 33	0.574448
29 and 34	0.574472
30 and 35	0.574446
31 and 36	0.574431
Average.....	0.574462

Although the average result is very slightly higher than the value which has already been shown by Baxter<sup>1</sup> to be the most probable one, 0.574453, the difference, which is less than 0.002%, is too small to be significant.

In examining critically the results recorded in the foregoing tables it should first of all be noted that a given percentage error in the experimental work is multiplied nine times in the calculation of the atomic weight of phosphorus; that is, an experimental error of one one-hundredth of a per cent. affects the atomic weight of phosphorus by 0.027 unit. The highest value for the atomic weight of phosphorus in these tables is 31.040, the lowest 31.013, a difference corresponding exactly to one one-hundredth of a per cent. in the experimental work. On the whole, however, the agreement of the results is better than this, since, of the thirty-six results, twenty-seven fall between the limits 31.035 and 31.021, a difference only half as large. In other words, the different specimens of material seem to be identical as far as the method is capable of testing this point.

In each series, if the first fraction, that of the highest number, 8 or 10, contained an excess of bromine, it would have yielded too low a result, while if decomposition occurred during the distillation, with the possible production of lower bromides of phosphorus, the residual fraction, 1, would have yielded too high a result. The only differences in each series,

<sup>1</sup> *Proc. Am. Acad.*, 42 (1906). *THIS JOURNAL*, 28, 1322. *Z. anorg. Chem.*, 50, 389.

however, seem to be purely accidental. Furthermore, the three series yield average results in practical unanimity.

In the following table the final average of this research is compared with that of Baxter and Jones with silver phosphate:

	Ag=107.88.	Ag=107.87.	Ag=107.86.
PBr <sub>3</sub> .....	31.027	31.024	31.021
Ag <sub>3</sub> PO <sub>4</sub> .....	31.04	31.03	31.02

### Summary of Results.

1. A method is described for the preparation of pure phosphorus tribromide.

2. It is shown that the precipitation of the halogen of phosphorus halides after decomposition with water, can safely be done only after the oxidation of the greater portion of the phosphorous acid produced.

3. A method is described for the determination of the bromine in phosphorus tribromide by comparison with silver and as silver bromide.

4. The molecular weight of phosphorus tribromide referred to silver 107.88 is found to be 270.775, whence phosphorus has the atomic weight 31.027. If silver is taken at 107.87, the atomic weight of phosphorus becomes 31.024. These values agree very closely with those found by the analysis of silver phosphate by Baxter and Jones.

An attempt to prepare and analyze phosphorus trichloride in a similar manner is now under way in this laboratory.

We are particularly indebted to the Carnegie Institution of Washington for generous pecuniary assistance in carrying out this investigation.

CAMBRIDGE, MASS.

---

## THE REDUCTION OF VANADIC ACID IN CONCENTRATED SULFURIC ACID SOLUTION BY HYDROGEN PEROXIDE AND BY PERSULFATES.

By J. R. CAIN AND J. C. HOSTETTER.

Received January 4, 1912.

Gregory<sup>1</sup> recently described a colorimetric method for vanadium depending on the colors developed when concentrated sulfuric acid solutions of vanadium and strychnine are mixed. It seemed likely from his statements and from others in the literature that the strychnine colors develop only with pentavalent vanadium. We satisfied ourselves that quadrivalent vanadium compounds, at least, give no colors. However, concentrated sulfuric acid solutions of vanadium containing small amounts of the latter are very apt, from various causes, to become reduced to quadrivalent vanadium when carrying out Gregory's method, and as we desired to avoid the use of potassium chlorate, as recommended by him, we tested various oxidizing agents. Among others, hydrogen peroxide

<sup>1</sup> *Chem. News*, 100, 221 (1909).